

## Operation manual for the



### Electro-magnetic valve ( Solenoid valve)

- for the control of the CO<sub>2</sub>- addition to aquariums
- for the control of reverse osmosis systems

The **AQUA MEDIC** CO<sub>2</sub> - solenoid valve is a product of highest quality, safe and reliable for more pleasure with your aquarium. A time dependant CO<sub>2</sub> – intake can be realised using a timer together with this valve.

The solenoid valve may also be monitored via a pH controller to achieve a maximum degree of comfort with ideal carbon dioxide provision at all times.

#### Technical specifications:

Function	2/2 directions, non-current carrying connection
Material	brass, chrome plated
Nominal width	2 mm, 0,08"
Operating pressure	0 –4 bar, 0 – 60 psi
Medium	gas, tap water
Connection	flexible hose, 6/4 mm (1/4")
Voltage	220 V, 50 Hz, if not otherwise noted
Power consumption	2,5 Watts
Operating factor	100%

#### 1. Operation with CO<sub>2</sub>

Installation Set up :

The solenoid valve is pre mounted and tested. It must only be integrated into the CO<sub>2</sub> – system . On the body of the valve, you find an arrow, that indicates the direction of the flow. First the hose is mounted on the inlet ( 4):

1. unscrew the knurled nut from the - CO<sub>2</sub> connection ( 4).
2. Slide the knurled nut over the flexible pressure tube.( 6/4mm, 1/4").
3. Slide the end of the tube over the nipple (4).
4. Screw the knurled nut onto the nipple and tighten.
5. Mount the other end of the flexible tube onto the pressure outlet of the
6. pressure reducer (**regular**) and tighten.
7. Now a tube is mounted in the same way on the outlet (5). Here, you do not need to use a pressure tube, you may use ordinary pvc- tube ( 6/4 mm, 1/4").
8. The free end is connected to the bubble counter inlet or to the CO<sub>2</sub> – inlet.

8. If you use a pressure regulator with adjustable operating pressure, set it to 1 – 1.5 bar( 14 – 20 psi).

Note: Always use a non return valve between the aquarium and the solenoid valve. It prevents water from flowing back from the aquarium into the regulator and the CO<sub>2</sub> – bottle and may cause damage. We recommend to use the original Aqua Medic bubble counter with integrated non return valve.

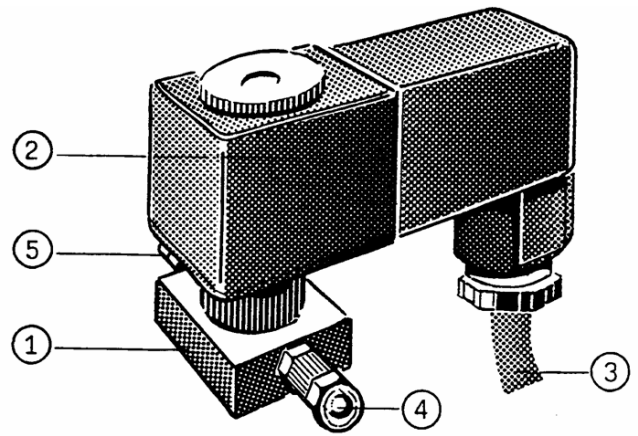

1. body of the valve
2. magnetic reel
3. power cord
4. CO<sub>2</sub>- inlet
5. CO<sub>2</sub>- outlet

### Operation with timer

The CO<sub>2</sub> –consumption during the day (light phase) is determined primarily by the plants. In the night ( dark phase), the plants excrete CO<sub>2</sub> –gas. So it is not necessary to provide CO<sub>2</sub> – during the night time, it may even be harmful. The solenoid valve can be linked to a timer to meet these specific requirements. An elegant solution is to connect the solenoid valve to the timer, that controls the lights. The valve is then switched on and off together with the light.

### Operation with pH controller

This operation mode should be preferred in comparison to others. It is the most exact and economical version. Only the exact quantity required is fed into the system. It balances the loss that is, for example caused by water movements and aeration. Fluctuations of the pH values are avoided by an electronic control. This is an advantage for the creation of a well balanced environment

## 2. Operation with water

The **AQUA MEDIC** solenoid valve may also be used for the control of smaller reverse osmosis systems. Some important points have to be taken care of, to avoid mistakes and damages:

- The reverse osmosis unit should not exceed a capacity of 150l/d (35gpd) of pure water. The small opening of 2 mm will cause pressure drops and decrease the capacity, if used with larger systems.
- If used with tap water, the solenoid valve may be blocked by dirt and rust. In order to avoid this, several precautions have to be taken:
- The solenoid valve has to be connected between the sediment filter and the RO module to protect it from clogging. The storage tank, where the water is collected should have a safety outlet to the drain. If used for marine aquariums, the evaporated water should not be refilled directly from the RO unit. It is recommended to collect the RO water in a separate tank and to provide the aquarium from this tank.

The solenoid valve may not be operated with sea water or pure water (reverse osmosis)

- technical changes reserved

